

Dear Client! Thank you for purchasing a Sigma mobile product!

Please read this manual before using the device to ensure safe and proper use and prevent it from damages.

- The software, design features and the content of the manual may be changed to improve the product without a prior notice.
- Manufacturers and distributors are not liable for damages of the frame as well as damages caused due to incorrect or improper exploitation.

WARNING! Protection against dust and water

- This phone was manufactured to meet the IP68 ingress protection standard, which means that its structure provides maximum protection from water, dust and dirt particles penetration. Follow the recommendations below in order to preserve the water- and dust-protective properties of your device.
- The phone has been tested and certified for water and dust resistance in accordance with international standards (IEC 60529 "Degrees of Protection Provided by Enclosures [IP code]") under the following conditions: 15-35 °C, fresh water, submersion up to 1.5 m, for 30 minutes. Notwithstanding compliance with these requirements, the device may still be damaged in some situations.
- Be careful with the phone's rubber plugs when used in water, and observe general safety rules. Carefully close the plugs covering the openings of the USB Type-C connector, headphone jack and the compartment for SIM / microSD cards.
- Do not immerse the device in water at a depth exceeding 1.5m and do not keep it in water for more than 30 minutes.
- Do not immerse the device in any liquid other than fresh water, such as salty water or alcoholic beverages. Such liquids may penetrate the device faster.
- Do not connect the charger immediately after moisture enters the phone. Wipe the device thoroughly if wet. If another liquid, e.g. salty water or alcohol, has gotten onto the device, wash it with fresh water and wipe it thoroughly. Failure to follow these guidelines may affect the operation and appearance of the device.
- When the phone is immersed in water or water enters the microphone or speaker openings, there may be a temporary deterioration in sound when playing music. Sound quality will be restored after full drying.
- The touchscreen and some features of the phone may not work properly when used in water or after immersion in water.
- Do not expose the appliance to water pressure.

- Shock resistance is not regulated by the standard. The phone, due to additional seals and strong fasteners, has better vibration resistance, but requires careful use. Dropping or striking the phone may result in the deterioration of the phone's resistance to water and dust penetration.
- The openings for microphone and speakers, as well as the atmospheric pressure compensation opening next to the phone's camera, are protected by waterproof membranes. Damage to these membranes will result in the loss of waterproof properties and void warranty repair.
- If the moisture in your phone is not caused by factory defects and mechanical damage or loosely closed plugs, warranty repair of the device will not be carried out.

Package Contents:

- Smartphone Sigma mobile X-treme PQ58
- AC Charger
- USB Type-C Cable
- Glass screen protector
- OTG Cable
- User's Guide
- Warranty Card

Size of the device: 173mm*79mm*14(20)mm

The manufacturer reserves the right to change the configuration, technical characteristics and appearance of the product.

Specifications

OS Android™ 13	Appreciate Android's new personalization capabilities. Thanks to the development of Material You, you can customize colors, themes and languages in apps. Even the media player will suit your music taste. Android starts protecting your data as soon as you turn on your device. With Android 13, you get more control over what data, such as photos, videos, and clipboard content, can be accessed by apps.
Screen	6.58" Resolution 1080*2408
Processor	Mediatek Helio G99, 8 cores up to 2.0 GHz*.
Camera	200 MP and 24 MP (night vision) on the back of the device, for photography and video

	recording, 32 MP on the front side for photography and video calling
Memory	RAM – 12 GB, ROM – 256 GB**. It is possible to expand the storage capacity with microSD cards up to 2 TB
Dual SIM, 3G, LTE	2 SIM cards with support for 3G and LTE technology – for using mobile data and with the ability to make calls
WI-FI 802.11 b/g/n/ac	Wireless network connection interface
GPS	Ability to determine your location and use navigation apps
Battery	6280 mAh
Telephone, frequency bands	GSM 900: 880-915 MHz (Tx), 925-960 (Rx) GSM 1800: 1710-1785 MHz (Tx), 1805-1880 (Rx) WCDMA uplink: 1920-1980 MHz, 880-915MHz WCDMA downlink: 2110-2170 MHz, 925-960 MHz LTE: downlink 1805-1880 MHz, 2620-2690 MHz LTE: uplink 1710-1785 MHz, 2500-2570 MHz
Bluetooth, Version, Frequency Band	V5.2 2402-2480 MHz
WI-FI frequency bands	2412-2472 MHz
Max radiated power in the frequency bands in which the radio equipment operates	Bluetooth: -3.13 dBm (0.5mW) GSM900: 32.40 dBm (1.74 W) GSM1800: 28.70 dBm (740 mW) WCDMA: 22.60 dBm (182 mW) LTE: 25.61 dBm (364 mW) WiFi: 13.54 dBm (23 mW)

*Processor frequency may be programmatically limited to lower values

**Actual memory size may be less due to pre-installed operating system and applications

Content

Content	4
Safety & Security	5
GET STARTED	6
Buttons and ports	7
Standby mode	7
Button to enter the additional menu	8
Connection to 3G/4G networks	8
Indicator icons	8
Charging the Battery	9
Inserting the SIM card and memory card	11
BASIC operation techniques	12
Using the Touch Screen	12
Setting Up Accounts	15
File Transfer	16
Protect your device	16
SETTINGS	17
Network & Internet	17
Connected Devices	19
Apps	20
Notifications	21
Battery	21
Storage	21
Sound & Vibration	21
Display	21
Wallpaper	22
Accessibility	22
Security	22
Privacy	23
Location	24
Safety & Emergency	24
Passwords & Accounts	24
Digital Wellbeing & Parental Controls	24
Google	25
DuraSpeed	25
Additional settings	25
System	26
About phone	27
COMMUNICATION	27
Phone	27
Receiving Calls	29

Missed calls	29
Contacts.....	29
Options available during the call.....	30
Notice.....	30
applications.....	31
Google Play Store	31
Camera	31
Google Apps	33
Troubleshooting.....	34

SAFETY & SECURITY

- Do not disassemble or repair the device yourself. In the event of a malfunction, contact the service center.
- Permissible ambient temperature in operating mode: from -20 to +50* C.
- Storage temperature: from -5 to + 45 * C.
- Relative humidity: 5% to 90% non-condensing (25 * C).
- Avoid contact of the unit with sources of fire to avoid explosion or fire.
- Don't expose your phone to temperatures that are too high or too cold.
- Avoid dropping the device and hitting other objects.
- Do not expose your phone to strong mechanical stress.
- The manufacturer is not responsible if the screen is damaged by the user.
- Avoid contact of the device with sources of electromagnetic radiation.
- Do not use chemicals or detergents to clean the product; Always turn off your phone before cleaning.
- Don't disconnect your device from your PC while formatting or copying files.
- When using the product as a removable drive, always strictly follow the instructions for performing the operations. Any erroneous action can lead to the loss of files.
- Back up important data on your PC, as device repairs or other reasons can lead to data loss.
- Use only manufacturer's recommended accessories.
- The phone does not contain substances harmful to health (according to DSTU EN50581).
- Dispose of the used battery at the end of its service life in accordance with the requirements of the law. Non-compliance with the norms of the legislation on disposal entails legal liability.

Headset usage

- For road safety, do not use the device with headphones if you are driving or cycling.
- Turn down the volume as you walk through the roadway.
- When using headphones, avoid listening to music at a low volume for a long time - otherwise it can lead to hearing problems.
- Stop using the device or turn down the sound if you hear ringing in your ears.

GET STARTED

Power on: Press and hold the power button for a few seconds. Wait for the device boot process to finish and the lock screen to appear.

Power off: Press and hold the power button for about 3 seconds until the power off interface window appears. Select the option that confirms the shutdown. The device will turn off.

Buttons and ports

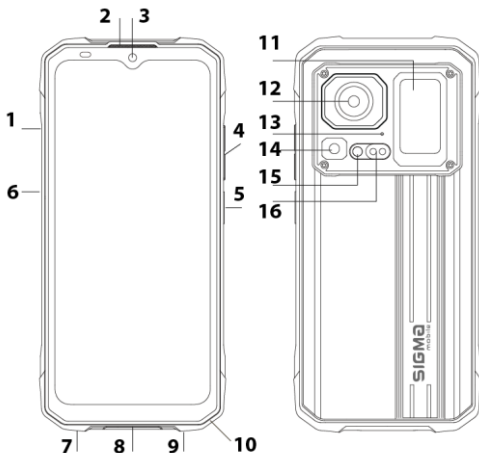

1	SIM/microSD slot	9	Speakerphone
2	Speaker	10	Strap eye
3	Front Camera	11	Mini screen
4	Volume	12	Main Camera
5	Power On/Off / Fingerprint Scanner	13	Atmospheric pressure compensation membrane
6	Shortcut key	14	Flash / Flashlight
7	Microphone	15	Night Vision Camera
8	USB Type C connector (under the cover)	16	IR LEDs

Standby mode

In operating mode, a short press on the power button will put the device into standby mode, the screen will turn off.

A short press on the power button again will exit the unit in this mode, and the lock screen will appear on the display.

To unlock your smartphone, swipe up from the bottom on any part of the screen.

It is possible to protect yourself from unauthorized access in several ways:

- Patterned locking;
- Locking with a password or pin code;
- Lock with Face Authentication
- Fingerprint Lock

Button to enter the additional menu

On the main screen and in various applications, there may be an icon . When you click on it, an additional pop-up menu will open for settings and controls.

Connection to 3G/4G networks





To activate the 3G/4G function*, insert the SIM card of the mobile operator in a special slot on your smartphone. Only then turn on the device, the search for a 3G/4G network signal will happen automatically.















* Turn off the Wi-Fi connection before starting the 3G/4G function (if the phone was connected via WiFi)

Attention! Before changing or removing the SIM card from the device, turn off the device beforehand to avoid damage to the card. Use SIM cards of universal size (SIM / MicroSIM) with caution, as the SIM to MicroSIM conversion groove can damage the contacts of the SIM card slot. The use of SIM card adapters is not recommended. Insert and remove the SIM card effortlessly. Mechanical damage to the connector is not a warranty case.

Indicator icons

Icons displayed at the top of the screen indicate the status of the device. The table below lists the most common icons.

	No Signal
	Signal Strength
	Roaming (outside the main operator's network)
	EDGE Data Transfer

	UMTS Data Transfer
	LTE Data Transmission
	Connected to a Wi-Fi network
	Bluetooth function enabled
	GPS Enabled
	Challenge in progress
	Missed call
	Synchronization with the web server is in progress
	New SMS or MMS
	Alarm On
	Do Not Disturb mode is on
	Vibration Mode Enabled
	Airplane mode is on
	An error has occurred or the user's attention is needed
	Battery level

Charging the Battery

Before you start using the device, you need to charge the battery using the charger.

Use only chargers, batteries, and cables recommended by Sigma mobile. The use of unapproved chargers or cables may cause the battery to explode or damage the device.

- When the battery is running low, the battery icon is displayed as an empty battery.
- If the battery is completely discharged, it will take some time for the device to turn on after connecting the charger. Allow a dead battery to charge for a few minutes before turning on the device.
- If you use multiple apps at the same time, or if you use network apps or apps that require you to connect to another device, the battery will drain quickly. To avoid unplugging or discharging during data transmission, always charge the battery before using such apps.

Charging with the charger

Connect the USB cable to the USB power adapter, then insert the other end of the USB cable into the multi-function jack.

Improper connection of the charger can cause serious damage to the device. The warranty does not cover damage to the device caused by improper use.

You can use your device while it's charging, but it will take longer for the battery to charge.

If the power supply is unstable while charging the device, the touch screen may not work. In this case, disconnect the charger from the device.

The device may become hot while charging. This is normal and does not affect its operation or lifespan. If the battery gets hotter than usual, charging with the charger may stop.

If the device does not charge properly, take it and the charger to a Sigma mobile service center

Once the battery is fully charged, disconnect the charger from the device. Unplug the charger from the device first, then unplug it from the power outlet.

To save power, unplug the charger when not in use. If the charger does not have a power switch, it should be unplugged from the electrical outlet when not in use to save power. When charging, the charger must fit snugly into a power outlet and be easily accessible.

Inserting the SIM card and memory card

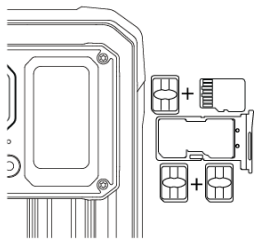

Install a SIM card (nanoSIM format) provided by your mobile operator and, if necessary, a microSD card.

1. Carefully remove the tray in which the SIM and microSD cards are placed.
2. Install a SIM card and, if necessary, a microSD card.

Attention! It is possible to use either two SIM cards (nanoSIM format) or one SIM card (nanoSIM) and a microSD card at the same time. Do not insert the memory card into the SIM card slot. If

the memory card is stuck in the SIM card slot, take the device to an authorized Sigma mobile service center to remove it safely. Be careful not to lose your SIM card and do not allow others to use it. Sigma mobile is not responsible for any damage or inconvenience caused by lost or stolen cards.

3. Install the tray in the appropriate slot and lock it.

Attention! An incompletely inserted tray and an incorrectly closed plug may cause liquid to enter the device.

Attention!

The device supports memory cards with a maximum capacity of up to 2 TB. Some memory cards may not be compatible with the device, depending on the manufacturer and type of card.

- Some memory cards may not be fully compatible with the device. Using an incompatible memory card may damage the device, the memory card, or the data stored on the card.
- Be careful to insert the card with the desired side facing up.

- This device supports FAT and exFAT file systems for memory cards. If you insert a card formatted in a different file system, the device will prompt you to reformat the memory card.



How will you use this SD card?



Use for extra phone storage

For apps, files, and media on this phone only

Phone storage

OR



Use for portable storage

For transferring files and media between devices

Portable storage

- After installing the memory card, the system will offer two use cases: "As Extra Phone Storage" or "As a Portable Storage". Read the information carefully before choosing a use case. The first scenario for using a memory card will allow you to transfer installed applications from the internal memory to the memory card. Special formatting of the memory card will not allow it to be used in other devices (phones, PCs, etc.). The second scenario of using a memory card is designed to store and transfer media files (when connected to a PC, you will be able to operate with files on the memory card – copy/delete/view, etc.).
- Writing and erasing data on a regular basis reduces the lifespan of memory cards.

BASIC OPERATION TECHNIQUES

Using the Touch Screen

Use only your fingers when using the touchscreen.

Attention! Do not allow the touch screen to come into contact with other electrical devices. Electrostatic discharges can cause the touch screen to malfunction. To avoid damaging the touchscreen, do not press it with sharp objects and avoid pressing it too hard with your fingernails. Touch input may not be recognized by the device in areas near the edges of the screen that are outside the touch area. Keeping the touchscreen standby for a long time can lead to image retention (screen burn-in) or ghosting. If the device is not in use, turn off the touch screen.

Finger control

Topping

To launch the program, select a menu item, press the on-screen button, or enter a character using the virtual keyboard, tap on any of these objects with your finger.

Tapping & holding

Tap and hold an item for longer than 2 seconds to open the available options.

Dragging

To move an icon, thumbnail, or previous image to a new location, touch and hold it, and drag it to the desired location.

Double Tapping

Double-tap a webpage or image to enlarge it/part of it. Double-tap again to return to the original scale.

Swiping

Swipe left or right on the home screen or apps screen to switch to a different panel. Swipe up or down to scroll through a web page or list, such as a contact list.

Spreading and pinching

Spread two fingers apart while placing them on the screen while viewing a web page, map, or image to zoom in on a part of it/it. Pinch them together to zoom out.

Screen rotation

Many programs support displaying the interface in portrait or landscape format. When the device is rotated, the interface rotates automatically according to the new orientation of the screen.

If you don't want the interface to change its position, open the notification panel and deselect the Screen rotation option.

Attention! Screen rotation is not supported in some apps. Some apps may display different screens depending on the orientation of the device.

Notifications

Notification icons appear in the status bar at the top of the screen, letting you know about missed calls, new messages, calendar events, device status, and more. Drag the status bar down to open the notification area. Scroll through the list to see additional warnings. To close the notification panel, drag a row from the bottom of the screen to the top.

In the notification panel, you can view your device's current settings. Swipe down from the status bar to use the following options:

- Settings : Go to your device's settings
- Wi-Fi: Wi-Fi function on/off
- Mobile data on/off, additional settings
- Airplane Mode: Turns airplane mode on or off.
- Bluetooth: on/off, additional settings
- Auto-rotate (screen rotation): turning automatic screen rotation on/off.

- Flashlight: on/off.
- Battery saver mode: on/off
- Night screen mode: on/off
- Do not disturb: on/off
- Location: Turns GPS on or off.
- NFC: On/Off
- Underwater mode: on/off
- Adjusting the screen brightness

To edit the notification panel (add/remove buttons, rearrange them), press the Edit key 

Home Screen

The home screen is the starting point from which all the functions of the device can be accessed. It displays indicator icons, widgets, shortcuts to quick access to applications, etc. All apps installed on your device appear on the home screen.

There can be more than one panel on the home screen. To see more panels, scroll left or right.

Arranging objects on the home screen

Moving items

Touch and hold an item, then drag it to a new location. To move an object to another panel, drag it to the edge of the screen.

Removing items

Tap and hold an item, then drag it to the trash can (or to Delete), which appears at the top of the home screen. When the basket turns red, release it.

Folders usage

You can combine multiple shortcuts into folders on your home screen. To do this, press and hold your finger on one of the shortcuts for a while, then drag it to another shortcut with which you want to merge into one folder.

On the Home screen, you can perform the following actions with folders:

Open the folder with a light touch of your finger.

Rename a folder by tapping its name with your finger.

Move folders and shortcuts on the desktop: Press and hold your finger, then drag the folder to the desired location.

Managing panels

Adding a new panel

A new panel is added automatically when a new object is added outside of existing panels

Moving a panel

From the home screen, tap and hold an empty area. Opens Preview of existing panels. Select a panel, press and hold its previous image, and then drag it to a new location.

Deletinh a panel

A panel is deleted automatically when you delete (or move) all objects from it.

Wallpaper settings

Set an image or photo stored on your device as the background for your home screen.

- From the home screen, touch and hold an empty area, then tap *Wallpapers*.
- Tap *Change wallpaper*
- Tap On-device *Wallpapers* to select ready-made wallpapers. To select photos taken with your device's camera or other images, tap *My Photos*
- Select the image you want, resize the frame (if necessary), and set it as your screen saver.

Using widgets

Widgets are small apps that bring handy features and information to your home screen. To use them, add widgets from the widget panel to your home screen.

Attention! *Some widgets connect to web services. Using a web widget may incur additional costs. Widget availability may vary by country or carrier.*

From the home screen, tap and hold an empty area, then tap **Widgets**. Scroll up/down/left/right in the widget panel, then tap and hold the selected widget to add it to your home screen. Position it where you want it, resize it by dragging the frame (if necessary), and then tap anywhere on the screen to save the widget's location.

Setting Up Accounts

A Google account is required to use Google apps such as Google Play, Gmail, etc. Create a Google Account to get the most out of your device.

Adding Accounts

To set up your Google Account, follow the instructions that appear when you open the Google app without signing in.

To sign in with or sign up for a Google Account, on the apps screen, tap

Settings  → Passwords & Accounts → Add Account → Google. Then,

enter your login email address or tap **Create Account** and follow the on-screen instructions to complete your account setup. You can use more than one Google Account on your device.

Removing Accounts

On the apps screen, tap **Settings** → **Passwords & accounts**, select the account (by tapping it) you want to delete, then tap **Remove account**

File Transfer

Transfer audio, video, pictures, and other types of files from your device to your computer and vice versa.

Connect in File Transfer Mode

- Connect your device to your computer using a USB cable.
- Go to **Settings**→**Connected Devices**→**USB** and select **File Transfer**
- Transfer files from device to computer or from computer to device.

Connecting in Photo Transfer Mode

- Connect your device to your computer using a USB cable.
- Go to **Settings**→**Connected Devices**→**USB** and select **PTP Mode**.
- Transfer photos from your device to your computer or from your computer to your device.

Protect your device

Protect personal data and information stored on your device from being used by other users and prevent unauthorized access to them with features Protection. You'll need to enter an unlock code each time you unlock your device.

Setting a pattern

On the apps screen, tap **Settings** → **Security** → **Screen lock** → **Pattern**. Draw the pattern by connecting four or more points, and then draw the pattern again to confirm it. Set a backup unlock PIN to unlock the screen in case you forgot the unlock sample.

Setting a PIN

On the apps screen, tap **Settings** → **Security** → **Screen lock** → **PIN**.

Enter at least four digits, then re-enter your password to verify it.

Setting a Password

On the apps screen, tap **Settings** → **Security & Location** → **Screen lock** → **Password**.

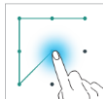

Enter at least four characters, including numbers and letters, and then re-enter your password to confirm it.

Installing a fingerprint to protect the device.

This phone has the ability to set up protection using the fingerprint sensor. To set up, tap *Settings* → *Security* → *Face And fingerprint unlock*. You'll need to scan one or more fingerprints and specify a backup screen lock method. When you install a fingerprint, you will need to touch the fingerprint sensor to unlock your phone each time you unlock it.

Set up unlocking your phone with facial recognition

This phone has the ability to set up protection using face recognition. To enable the function, you must first set a key or PIN code to unlock. After that, go to *Settings* → *Security* → *Face And fingerprint unlock* to scan your face or control those already saved. Once you've set up the function to unlock your phone, it is enough to hold your phone in front of the face that has been pre-configured after turning it on. Footprint Remember that facial recognition is less secure than a key, PIN, or password

SETTINGS

Use this app to customize device settings, install app options, and add accounts.

Tap Settings on the apps screen.

Network & Internet

Internet

This section contains settings related to the device's connection to the Internet: mobile Internet and WiFi settings.

Tap in the line with the name of your carrier to go to the SIM card menu:

- Enabling/disabling the SIM card
- Enabling/disabling mobile data
- Enabling/disabling data roaming
- Network selection method: auto or manual

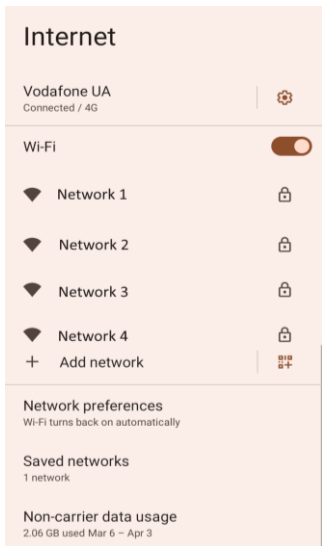

- Setting limits and warnings when using mobile Internet
- Configuring Access Points
- View usage statistics
- Choice (in case of two SIMs) SIM card for calls and SMS

To turn on  Wi-Fi, tap the switch

When you enter the Wi-Fi section, you will see a Wi-Fi switch, a list of available networks, the last line of which is "Add network" - for manually adding a Wi-Fi network.

Saved networks - a list of saved networks;

To switch to settings, tap Network Settings:

- Automatically turn on Wi-Fi – Turn on Wi-Fi within range of saved networks
- Network alerts (toggle) - notifications about available networks;
- Install certificates;
- Wi-Fi Direct

Once you've set your connection and wireless network settings, you'll see an icon at the top of the screen . To view information about your

connected network, tap  in the connected network bar.

Mobile network

Mobile Data

Enabling/disabling mobile data

Roaming

Enabling/disabling data roaming

App Traffic Usage

View mobile data usage statistics

Preferred Networks

List of mobile networks

Network Type

Selecting a 2G/3G/4G network type

Choosing a network operator

Manual / Automatic Network Operator Selection

Access Point Names

Configuring Access Points for Data Transfer

Airplane Mode

Turn off all wireless features on your device. Only non-networking services may be used.

SIM cards

Enabling/disabling SIM cards, default card settings for:

- Retrieving mobile data
- Calls
- Messages

Hotspot & tethering

WiFi hotspot: Use a portable mobile hotspot to share your device's connection to your mobile network via Wi-Fi with computers or other devices.

USB tethering: Use a USB tether to share your device's connection to your mobile network with computers over a USB connection. Once connected to your computer, your device is used as a wireless modem for your computer.

Bluetooth tethering: Use Bluetooth tethering to share your device's connection to your mobile network via Bluetooth with computers or other devices.

Ethernet tethering

Saving data

Set mobile data usage limits for individual apps.

VPN

Set up and connect to virtual private networks (VPNs)

Connected Devices

USB

Choosing the type of USB use (when connected to a PC):

- File Transfer
- USB Modem Mode
- Use the device as MIDI

- Transfer Photos (PTP Mode)
- No Data Transfer (Charging Only)

Connect a new device

Find and connect a new Bluetooth device.

Previously connected devices

List of Bluetooth devices that have already been connected to your smartphone

Connection preferences

Bluetooth

Turn on Bluetooth to share information over a short distance.

NFC

Turn on NFC and install the contactless payment app

Cast

Turn on the wireless screen and find devices to connect to

Printing

Connecting to the Printer and Setting Up

Quick Share

Share files with nearby devices

Android Auto

Use apps on your car's screen

Apps

A list of apps installed on the device.

To see all installed apps, tap *All apps*. Tap the app you want to view and customize your actions:

- Open
- Uninstall – Uninstall an app
- Force Stop – Temporarily pause the app
- Notifications – Set up notifications for the app
- Permissions – View and configure app permissions
- Storage and cache - the app's use of the device's memory
- Mobile Data & Wi-Fi - Data Usage
- Battery. Data about the app's battery usage, background settings, and battery optimization.
- Device Usage Time
- Open by default (using this particular app to open specific links)
- App Info

Attention! You can't uninstall the default apps that come with your device. You can't turn off downloaded apps or some standard apps that come with your device. When you use this feature, disabled apps stop appearing on the app screen, but are still stored in your device's memory.

Default Apps

Set the default add-ons that will be used in certain situations.

Screen Time

Device usage statistics, timer settings for apps

Cloud-based multimedia application

Choosing a media content provider from the cloud.

Unused Apps

List of Unused Apps

Special app Access

Configuring special access of applications to system processes.

Notifications

For each application, you can enable/disable and configure the display and sending of notifications in different situations of smartphone use. View your notification history.

Battery

In this menu, you can see the battery usage after the last full charge, turn on/off and adjust the power saving mode, turn on the battery percentage display, and more.

Storage

Display of the memory installed in the device: total capacity and free space. Enabling/disabling the memory manager to automatically manage the device's memory.

Sound & Vibration

Phone sound settings: ringtones and their volume for different types of notifications, enabling/disabling vibration, key sound, Do Not Disturb mode settings, sound boost mode settings, and more.

Display

Screen Settings:

- Brightness level
- Adaptive Brightness (Toggle)
- Options for displaying notifications on the lock screen
- Screen Timeout
- Dark Theme (Toggle & Schedule)

- Display size and text: Adjust the font size on the screen
- Night Light (Toggle & Schedule)
- Auto-rotate screen (toggle)
- Screen refresh rate
- Screen saver
- Lift to wake (toggle)

Wallpaper

Set a wallpaper

Accessibility

Accessibility Services are special features designed for users with specific physical limitations. Use and modify settings to improve device accessibility and usability

Security

Security Status

- Enabling/disabling Google Play Protect and its report
- Turn on and set up Find My Device

Device Security

Change your device's security settings

- Screen lock. Setting the lock screen type.
- Face and fingerprint unlock. Set up screen unlocks by scanning the owner's face with the camera and/or using a fingerprint. When setting up, you must also specify one of the backup ways to unlock the screen: Key, PIN code, Password

More security settings

- Smart Lock. To turn it on, you need to set up a screen lock. With Google Smart Lock, you can easily protect your devices and accounts. Smart Lock automatically locks your tablet or phone when it's not with you and unlocks your device when it's safe. You can choose how to unlock your Android device: through certain Bluetooth or NFC connections, in trusted places, when you hold it, or when it recognizes your voice
- SIM Lock Settings:
 - Lock SIM: Enable or disable the PIN lock feature to prompt for a PIN before using the device.
 - Change SIM PIN: Change the PIN used to access the data on the SIM card.

- **Device Administrators:** View the administrators of the device installed on the device. Device administrators can be allowed to apply new policies to the device.
- **Storage Type:** Sets the type of storage location for saving credential files.
- **Strong credentials:** Using certificates and credentials to use a variety of applications securely.
- **Installing Certificates:** Installs encrypted certificates stored on a USB drive.

Delete credentials: Erase the content with credentials from the device and reset the password.

Privacy

Privacy dashboard

Show apps that have recently requested permissions.

Permissions Manager

View app permissions. Permissions are grouped by usage type. It is possible to manage permissions: enable/disable

Camera access

Enable/disable camera access for all apps and services.

Microphone access

Enable/disable microphone access for all apps.

Show Passwords

Enabling/disabling the function of briefly showing the password while it is entered.

Notifications on lock screen

Choose how notifications are displayed, add users to text on the lock screen

Android System Intelligence

Getting a suggestion based on which people, apps, and content the user is interacting with.

App content

Switch. To allow apps to send content to the Android system.

Show clipboard access notifications

Switch.

Autofill service from Google

View and manage data that can be entered with a single tap, including passwords, addresses, credit cards, and other information stored in your Google Account.

Activity controls

Choose what information Google can store

Ads

Advertising ID & Personalization

Usage and diagnostics

Switch. Help improve the quality of Android by automatically sending diagnostics, device, and app usage data to Google.

Location

- Use Location – Toggle
- View recent location app queries
- Change settings for location permissions
- View Google Location History
- Google Location Sharing - Toggle
- Geolocation accuracy settings

Safety & Emergency

- Setting up emergency data: owner's medical data, contact persons for emergency situations
- Set up emergency calls
- Setting Up Emergency Alerts
- Enabling/disabling geolocation in case of emergency

Passwords & Accounts

Manage (add, edit, etc.) device accounts. Enabling/disabling automatic data synchronization.

Digital Wellbeing & Parental Controls

A system app that allows you to get information about how your device is used, such as how often your phone is unlocked, or how long each app has been running. Setting a sleep lock, setting timers for apps (when the timer time for an app expires, the app will pause for the rest of the day). Set up parental controls.

Google

The Google app keeps you informed about things that interest you. Search for quick answers, explore your interests, and get personalized updates on your Google feed. The more you use the Google app, the better it becomes. This section contains all the information and settings of Google services.

DuraSpeed

A system application that allows you to speed up the work of active applications by limiting the capabilities of applications running in the background. When enabling the function, it is possible to create a list of applications whose functioning in the background will not be limited

Additional settings

- Side key functions: Set the action to press, double-tap, press, and hold the side key
- MiniScreen settings
- Gesture motion. Set up actions for using your smartphone with a variety of gestures and controls: screenshot, quick launch of the camera, adjustment of the volume, unlocking, etc.
- Fingerprint. Manage and setup the fingerprint related functions
- Smart touch. A virtual movable button on the screen. Programmed to perform certain actions
- Gloves Mode, Switch
- Flashing when incoming call, switch
- Quickly open camera, switch
- One handed mode, switch
- System navigation. Choosing and configuring the way you navigate your phone:
 - Gesture navigation. In this case, the line with the navigation keys at the bottom of the screen will not be available.
 - Three-button navigation. It is possible to adjust the location of the navigation bar buttons
- Press and hold power button. Adjust the action when pressing and holding the power button: launch the Shutdown/Restart menu or Google Assistant

System

Language & Input

Change your text input settings. Some options may not be available depending on the language selected.

Language

Choose the language in which all menus and apps are displayed.

Keyboard

- Configuring the installed on-screen keyboards: language, theme, text correction, etc.
- Google Voice Typing
- Setting up a physical keyboard (when connected)

Tools

- Spell check
- Personal dictionary
- Text-to-speech: set the default system, select a language, adjust the pace and tone of speech
- Cursor speed adjustment

Date & Time

Access and change the following settings to control how time and date are displayed on your device.

If the battery is completely discharged or removed from the device, the time and date will be reset.

- Auto Date & Time: Automatically updates the date and time when moving between time zones.
- Automatic Time Zone: Retrieves time zone information from the network as you move between time zones.
- Date: Set the current date manually.
- Time: Sets the current time manually.
- 24-hour format: Displays the time in a 24-hour format.

Backup

- Back up your data: Back up your app settings and data to a Google server.
- Backup account: Manage backup Google accounts.
- Button to back up your data. Click to avoid waiting for a scheduled copy to be generated.
- View backup details

Multiple users.

Share your phone by adding new users. Allow multiple users, toggle

Reset options.

Reset Your Device

- Reset network settings: Delete WiFi networks and passwords, paired Bluetooth devices, mobile data settings
- Reset app settings.
- Restore Factory Settings: Reset settings to factory defaults and erase all data

About phone

Various information about the device, installed software, their versions, information for emergencies, etc.

COMMUNICATION





Phone

Use this app to make or answer calls.

Tap *Phone*  on the apps screen.

Making a call

Use one of the following methods:

- **PHONE:** To open the keypad  , tap , enter the number using the keypad, and then tap  .
- **Speed Dial (Favorites):** Tap Favorites  to make a call from your list of favorite contacts.
- **CONTACTS:** Tap Contacts  to make a call from your contact list.
- To view your call history, tap Recents  Recents

Favorites

To dial quick numbers, tap the contact.

Search for contacts

Type your name, phone number, or email address in the search box



Search contacts



to find the contact in your contact list.

As you type characters, predicted contacts will be displayed. Select one of them to make a call. Tap the icon to the left of Contact name to view the contact's details.

Tap  on the right side of the search box to access:

- View call history
- Go to settings:
 - Options for displaying numbers, sorting numbers
 - Sounds & Vibration: Set the default ringtone, turn on vibration, turn on numeric keypad presses
 - Quick Replies
 - Calling accounts: set a dialing rule when calling – use a default SIM card, or on request
 - Blocked numbers: A list of phone numbers from which calls and messages will be blocked
 - Voicemail: Voicemail Settings, Notification Settings
 - Other settings

Receiving Calls

Answering calls and rejecting a call

When you're on an incoming call, drag the



Swipe up to answer



Swipe down to decline

handset icon on the screen , swipe up to answer, and down to reject the call

To send a message if an incoming call is declined,

tap the decline message icon  and select the message. To edit the message that will be sent if a call is declined,

tap  → Settings → Quick Replies.

Missed calls

If there's a missed call, you'll see the icon in the status bar . Open the notification panel to go

to the list of missed calls.

Contacts

Use this app to manage your contacts, including phone numbers, email addresses, and more.

Tap **Contacts**  on the apps screen.

Contact Management

Tap **CONTACTS** on the apps screen.

Creating a contact

Tap , select where to save the contact, and enter your contact details. When you're done typing, tap **SAVE** to save your changes.

Edit a contact

Select (tap) the contact you want to edit, then tap .

Delete a contact

To delete a contact, tap  and select *Delete*.

Setting the Contact Ringtone







To set a ringtone for a contact, tap  and select *Ringtone*

Setting a Speed Dial Number

Tap the contact you want, tap , the icon changes to , the contact will appear in the Speed Dial (Favorites) panel. To remove a contact from the speed dial list, tap the icon again.

Options available during the call.

The following features are supported:



- Call hold. Tap  to hold, tap again to resume the held call.
- Speaker: Turn the speaker on or off, touch . When using the loudspeaker, speak into the microphone located at the bottom of the device and keep the device at a certain distance from your hearing organs.
- Open or close the keyboard, tap 
- Mute your microphone so the other person can't hear you. Tap 
- Add a call. Tap 
- Tap  to end the current call.

Notice

Send messages and view messages in conversations.

Messages

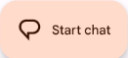
Attention! There may be additional charges for sending messages while roaming.

- Tap *Messages*  on the apps screen.
- Tap  to compose a new message
- Add recipients and enter the text of the message.
 - Tap  to send a message.
 - Tap and hold  to change SIM card, add a subject for a message, schedule a shipment.

View Messages

Messages are grouped into message threads by contact.

Attention! Receiving messages while roaming may incur additional charges.

- Tap *Messages* on the apps screen.
- Select a contact from the message list.
- Review the conversation.

Message settings

Tap *Messages* on the apps screen, tap the account icon on the right side of

the search bar  , tap Settings. In this menu, you can configure:

- Chat features
- Notifications
- Preview
- Spam protection
- Group Messaging Mode
- SMS Settings: Delivery Reports, Edit SMS Sending Center, SMS Input Mode
- Viewing SMS on a SIM card
- MMS Settings

APPLICATIONS

Google Play Store

Google Play is Google's app store that allows owners of Android devices to download and buy various applications, books, movies, and music. To go to

Google Play, tap  on the apps screen

Camera

Take photos and videos in different modes and settings.

Basic Shooting Functions

You can take photos and record videos. Photos and videos can be viewed in the Gallery.

Tap Camera on the apps screen.

Rules of conduct when taking photos and videos



- Don't take pictures or videos of people without their consent.

- Do not take pictures or videos in places where it is prohibited.
- Do not take photos or videos in places where the privacy of others may be violated.

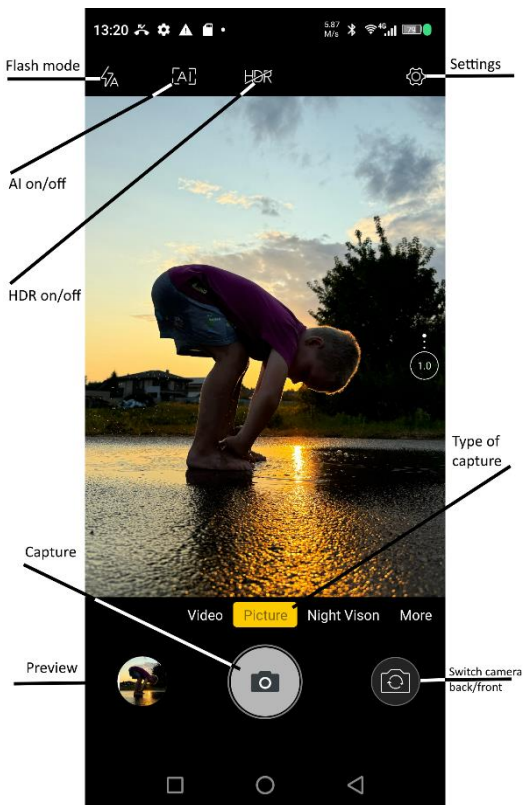
Taking photos and recording videos





- Choose the type of capture: Picture, Video, or other

- Tap the image on the preview screen at the point where you want the camera to focus.
- Place two fingers on the screen and spread them apart to zoom in or pinch to zoom out.
- Tap Capture  to take a photo or to take a video.
- To change focus during movie recording, tap where you want to focus.
- To go to settings, tap  Settings
- To view the photo or video you've taken, tap Preview.

Thumbnails of video files display the icon . To play the video, tap it.

To hide or unhide the menu, tap the screen.

- To select more options, tap 
- To send a photo or video, tap 
- To delete a photo or video, tap  and Delete

Attention! The camera automatically turns off when not in use. Make sure the lens is clean. Otherwise, the device may not work properly in some modes that use high resolution. The front camera has a wide-angle lens. Slight distortion may appear in wide-angle photos, which does not indicate a malfunction of the device.

Google Apps

Google provides apps for entertainment, social networking, and business. Some apps may require a Google Account. For more information, see Accounts.

To view more information about the apps, open the help menu for each app. Some apps may not be available or have a different name depending on your country or carrier.

Chrome

Fast, easy, and secure browsing with Google Chrome.

Gmail

Email from Google: Secure, smart, and easy to use.

Google Maps

Explore your world and navigate with Google Maps. Find your favorite places, connect with businesses you're interested in, and share real-time traffic information.

Google TV

Watch movies, episodes, live TV shows, and more on your favorite programs. Finding what to see is easier than ever.

Google Drive

All your files are accessible from any smartphone, tablet or computer. Anytime.

YouTube

Watch your favorite videos and playlists.

Google Photos

Google Photos is the home of all your memories that will help you find and relive all the important moments.

Google

Search quickly for information when you need it, from the nearest coffee shop to your next movie.

Voice search

Use the magic of Google Voice Search™ to find answers on the go without typing.

Google Settings

Customize the settings for some of the features provided by Google.

TROUBLESHOOTING

Before contacting the Sigma mobile service center, try using the following solutions. Some situations may not apply to your device.

After you turn on or use your device, you may be prompted to enter one of the following codes:

- Password: If the device lock feature is enabled, you must enter the password you set.
- PIN: The first time you use your device, or if you have enabled the PIN prompt feature, you'll need to enter the PIN that comes with your SIM or USIM card. This feature can be disabled using the "Lock SIM Card" menu.
- PUK: SIM or USIM card is blocked; This is usually the result of entering the wrong PIN several times in a row. In this case, you need to enter the PUK code provided by the telecom operator.

- **PIN2:** If you open a menu that requires you to enter a PIN2 code, you must enter the PIN2 code that comes with your SIM or USIM card. For more information, contact your carrier.

The device displays service and network errors

- In a place with a weak signal or poor reception, you can lose connection. Try to get in touch elsewhere. Error messages may be displayed repeatedly as you move.
- Some options are not available without a subscription. For more information, contact your carrier.

The device does not turn on

The device will not turn on when the battery is completely discharged. Fully charge the battery before turning on the device.

The touchscreen responds slowly or inappropriately

- If you use a screen protector or optional touchscreen accessories, it may not work properly.
- The touch screen may not function properly when used with gloves and when touched with dirty hands, sharp objects, or fingertips.
- The touch screen may not function properly in humid conditions or when exposed to water.
- Restart your device to resolve any temporary software errors.
- If the touch screen is scratched or damaged, take it to a Sigma mobile service center

The device does not respond to keystrokes, or a critical error has occurred in its operation

Try the following solutions. If the problem persists, contact a Sigma mobile service center

Restart your device

If your device doesn't respond to keystrokes or freezes, you may need to close apps or restart your device again.

Force reboot

If the device "freezes" or does not respond to keystrokes, press and hold the power on and off key and the volume down key at the same time for 30 seconds to restart the device.

Reset Device Settings

If the methods above do not solve the problem, perform a factory reset.

On the apps screen, tap Settings → System → Reset Settings → Erase All Data.

Before performing a factory reset, be sure to back up any important data stored on your device.

Calls Not Made

- Make sure you're connected to the correct network.
- Make sure that the phone number you're dialing isn't set to call barring.
- Make sure that your incoming phone number isn't set to call barring.

People can't hear you on a call

- Make sure that the built-in microphone is not blocked.

- Make sure to hold the microphone close to your mouth.
- If you're using a headset, make sure it's properly plugged in.

Audible echo during a call

Adjust the volume by pressing the volume rocker or move to a different location.

The cellular network or internet is often disconnected, or the sound quality is poor

- Make sure that the internal antenna of the device is not blocked.
- In a place with a weak signal or poor reception, you can lose connection. There may be connectivity issues due to service provider base station outages.
- Try to get in touch elsewhere.
- If you're using your device on the go, wireless network services may be disabled due to problems with your service provider's network.

Empty battery icon

The battery is dead. Charge the battery.

The battery does not charge properly (for chargers recommended by Sigma mobile)

- Make sure the charger is plugged in properly.
- Contact a Sigma mobile service center for battery replacement.

The battery drains faster than at the beginning of its use

- If the device or battery is exposed to very cold or very high temperatures, the usable charge may decrease.
- Battery consumption increases when you use messaging features or some apps, such as games or a browser.
- The battery wears out over time and its usable charge decreases.

The device is hot to the touch

When using apps that are actively consuming battery power, or when using apps for extended periods of time, your device may feel hot to the touch. This is normal and does not affect its operation or lifespan.

If the unit overheats or becomes hot, do not use it for a long time.

If the device has not cooled down for a long time, contact a Sigma mobile service center.

When the camera starts, error messages are displayed

The device's camera requires a sufficient amount of free memory and battery power to work. If you receive error messages when starting the camera, try the following:

- Charge the battery.
- Free up memory by transferring files to your computer or deleting them from your device.
- Restart your device. If you still encounter problems with the camera after performing these steps, contact the Sigma mobile service center.

The quality of the photos is lower than the preview

- The quality of the photos depends on the environment and the photographic technique used.
- When photographing in dark places, at night, or indoors, noise may occur or images may be out of focus.

Trademarks

- Google, Android, Google Play, YouTube and other trademarks are trademarks marks of Google LLC.
- Bluetooth® is a registered trademark of Bluetooth SIG, Inc. worldwide.
- Wi-Fi®, Wi-Fi Protected Setup™, Wi-Fi Direct™, Wi-Fi CERTIFIED™, and the Wi-Fi logo are registered trademarks of Wi-Fi Alliance.
- All other trademarks and copyrights are the property of their respective owners.